

# Series MC soft start valves

Ports G1/4, G3/8 and G1/2  
Modular



Series MC soft start valves are used to avoid damages to people or equipment when pressurising pneumatic systems containing cylinders.

The features of these components allow to pressurise an equipment up to 50% of the indicated pressure, after which 100% is reached rapidly.

The usual location of the soft start valve is after the FRL unit; in fact the modular design allows for perfect adaptability with all Series MC.

A pressure switch can be mounted to the upper part of the unit after removal of the S2610 G1/8 plug.

An electrical or pneumatic 3 way valve should be installed at the bottom of the unit to allow depressurisation.

## GENERAL DATA

|  |  |       |       |       |
|--|--|-------|-------|-------|
| Construction   | modular, compact, poppet type  |       |       |       |
| Materials  | zama, NBR, technopolymer   |       |       |       |
| Ports  | G1/4   | G3/8  | G1/2  |       |
| Weight   | Kg   | 0,275 | 0,566 | 0,544 |
| Mounting   | in-line wall or panel mounting (in any position)   |       |       |       |
| Operating temperature                                | -5°C ÷ 50°C (with the dew point of the fluid lower than 2°C at the min. working temperature) |       |       |       |
| Finishing  | enamelled  |       |       |       |
| Operating pressure                                   | 2 ÷ 10 bar   |       |       |       |
| Nominal flow (determined at 6 bar with $\Delta P1$ ) | G1/4 = 1850 NI/min, G3/8 = 4000 NI/min, G1/2 = 4350 NI/min                                   |       |       |       |

**CODING EXAMPLE**

|           |          |           |          |           |
|-----------|----------|-----------|----------|-----------|
| <b>MC</b> | <b>2</b> | <b>02</b> | <b>-</b> | <b>AV</b> |
|-----------|----------|-----------|----------|-----------|

|           |   |
|-----------|---|
| <b>MC</b> | SERIES  |
| <b>2</b>  | SIZE:<br>1 = G1/4<br>2 = G3/8 - G1/2          |
| <b>02</b> | PORTS:<br>04 = G1/4<br>38 = G3/8<br>02 = G1/2 |
| <b>AV</b> | AV = SOFT START VALVE                         |

**Soft start valve Series MC**  
X = adjustment screw

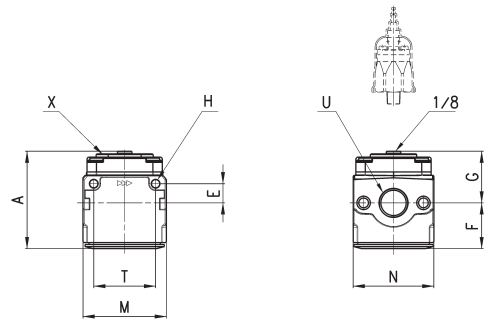
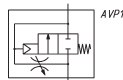

| DIMENSIONS      |      |    |      |      |     |    |    |    |      |  |
|-----------------|------|----|------|------|-----|----|----|----|------|--|
| Mod.            | A    | E  | F    | G    | H   | M  | N  | T  | U    |  |
| <b>MC104-AV</b> | 59,5 | 11 | 28,5 | 31   | 4,5 | 45 | 45 | 35 | G1/4 |  |
| <b>MC238-AV</b> | 72,5 | 14 | 34   | 38,5 | 5,5 | 62 | 60 | 46 | G3/8 |  |
| <b>MC202-AV</b> | 72,5 | 14 | 34   | 38,5 | 5,5 | 62 | 60 | 46 | G1/2 |  |

## DIAGRAMS FOR PRESSURISATION TIMES

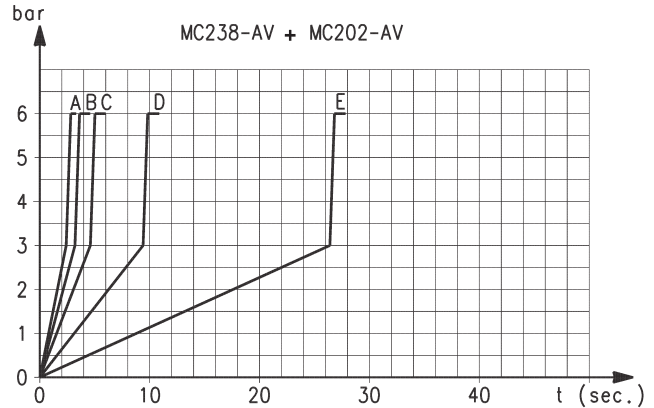
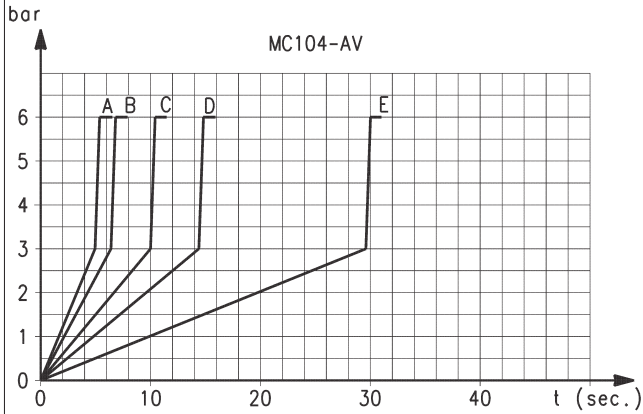

Pressurisation times as to the n° of turns of the regulation screw, with downstream volume of 5 litres. A = 5 turns - B = 4 turns - C = 3 turns - D = 2 turns - E = 1 turn. "K" = n° of turns of the regulation screw required to obtain the required pressurisation time with an inlet pressure of 6 bar. Variations of the inlet pressure can cause deviations of the pressure time by ± 20%.  $K = t/V$  where: V = volume of the downstream system in litres; t = desired pressurising time in seconds.

Pressurisation times as to the n° of turns of the regulation screw, with downstream volume of 5 litres. A = 9 turns - B = 7 turns - C = 5 turns - D = 3 turns - E = 1 turn. "K" = n° of turns of the regulation screw required to obtain the required pressurisation time with an inlet pressure of 6 bar. Variations of the inlet pressure can cause deviations of the pressure time by ± 20%.  $K = t/V$  where: V = volume of the downstream system in litres; t = desired pressurising time in seconds.

## VARIATION IN PRESSURISATION - Example

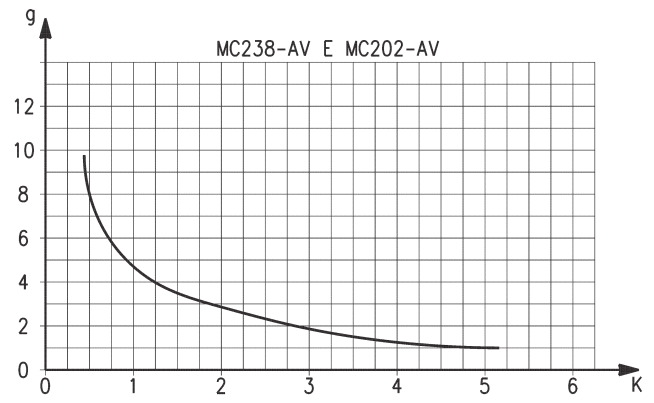
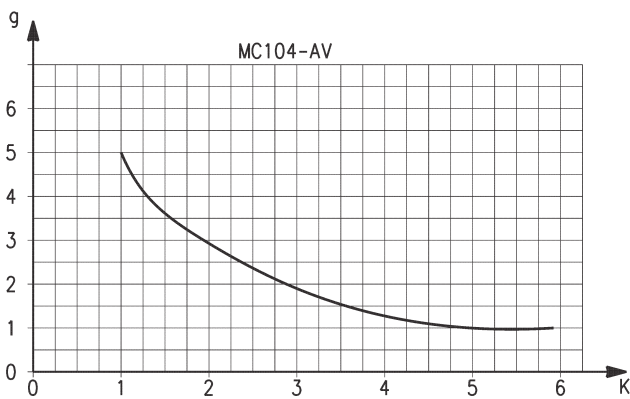

Example: MC104-AV

V = 5 litres

t = 16 seconds

$K = 16/5 = 3,2$

g = number of turns

Using in the graph this value K, the number of turns of the regulation screw will be approx. 1,8.

Example: MC238-AV - MC202-AV

V = 5 litres

t = 16 seconds

$K = 16/5 = 3,2$

g = number of turns

Using in the graph this value K, the number of turns of the regulation screw will be approx. 1,8.